

A - B
Avanti - Indietro
Ahead - Back
Avant - Derrière

C - D
Rotazione
Rotation
Rotation

E
Destra - Sinistra
Right - Left
Droite - Gauche

H
Alto - Basso
High - Low
Haut - Bas

F
Regolazione inclinazione antina
Regulation door inclination
Regulation inclinaison porte

Art. 265



Portata guida 100 Kg - Portata utile 80 Kg
Runners capacity 100 Kg - 80 Kg load capacity
Charge net des glissières 100 Kg - Charge net 80 Kg

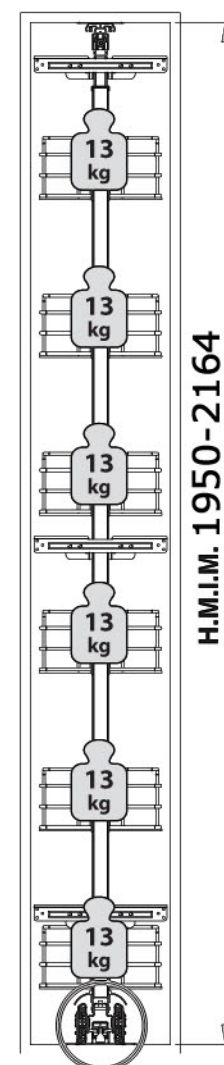

- A: Telaio inferiore - Lower frame - Chassis inférieur
- B: Telaio superiore - Upper frame - Chassis supérieur
- C: Guida inferiore - Shallow bottom runner - Glissière inférieure
- D: Guida superiore - Upper runner - Glissière supérieure
- E: Staffa attacco antina - Door bracket - Équerre de façade
- F: Reggi attacco antina - Door bracket frame - Équerre de chassis
- G: Inserto speciale di serraggio - Fixing support - Support spécial de fixation
- H: Ferno di serraggio - lockbolts - boulons de blocage

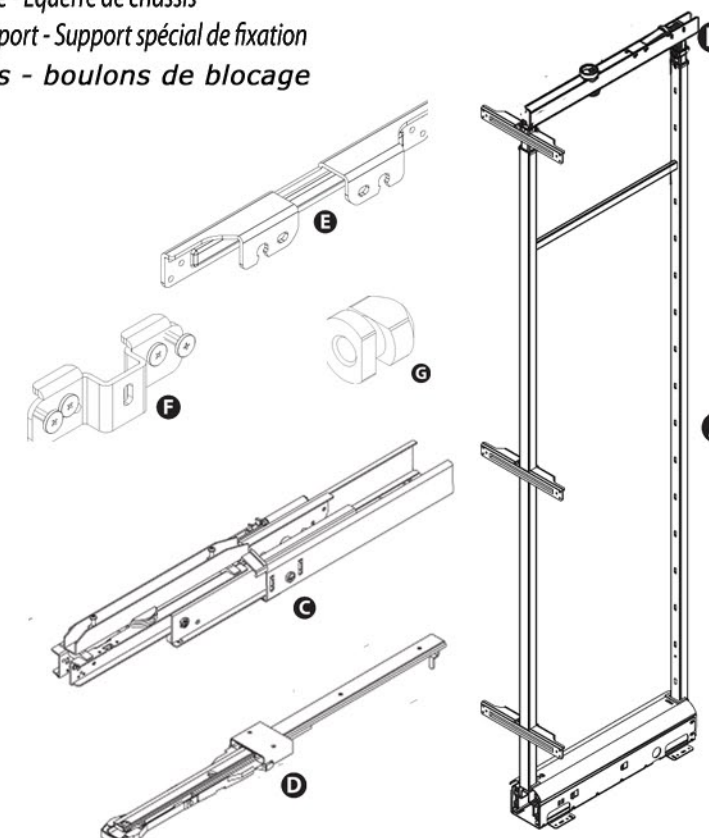
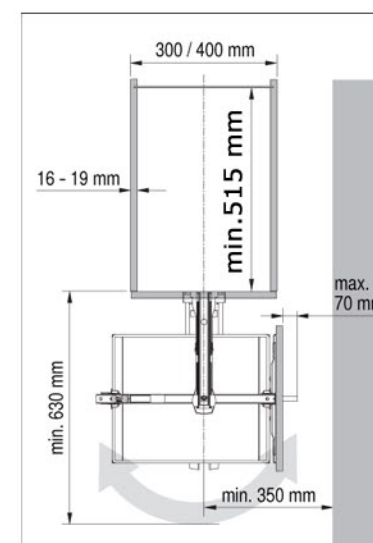

- 1** Posizionare la guida inferiore C rispettando le quote e avvitare con le apposite viti
Set the shallow bottom runner C respecting the distances and with fix the screws provided
Mettre en place la glissière inférieure C à la correcte distance et la fixer avec les vis fournies

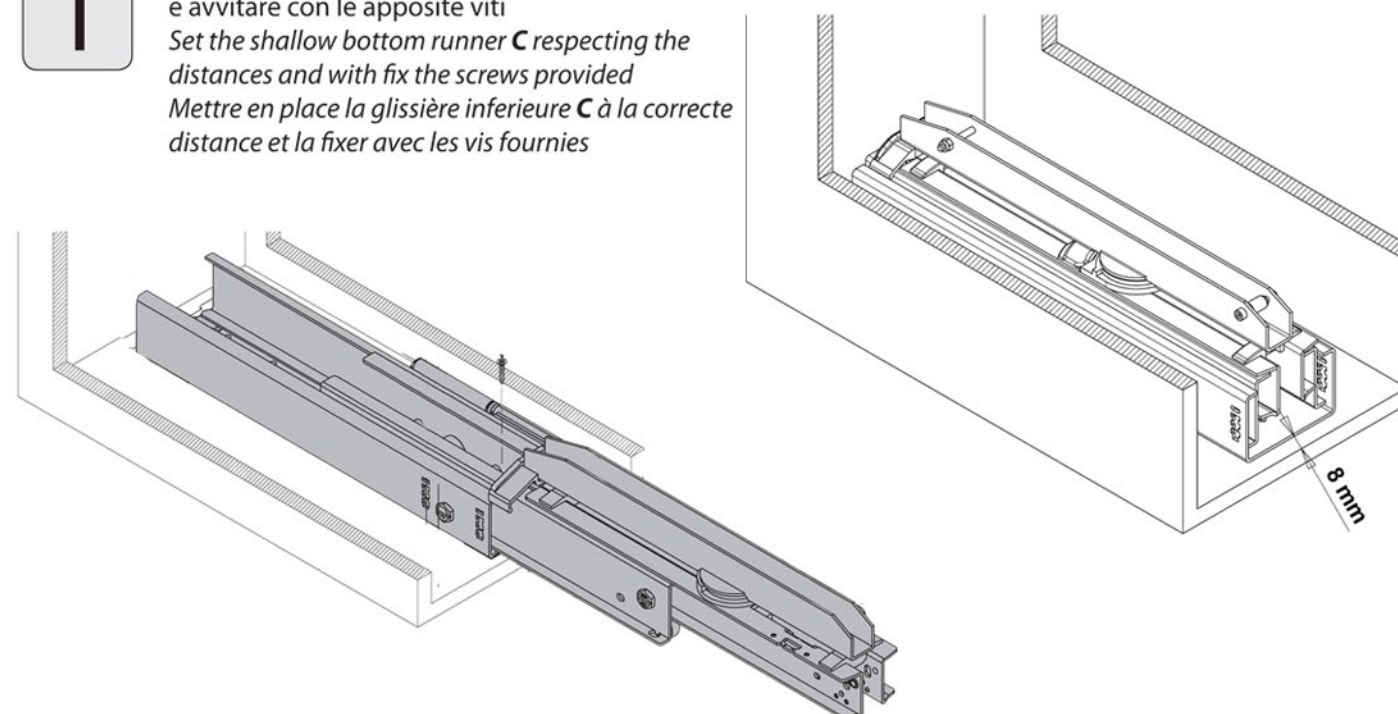

2

Posizionare la guida superiore **D** rispettando le quote e avvitare con le apposite viti
Set the upper runner **D** respecting the distances and fix with the screws provided
Mettre la glissière supérieure **D** à la correcte distance et la fixer avec les vis fournies

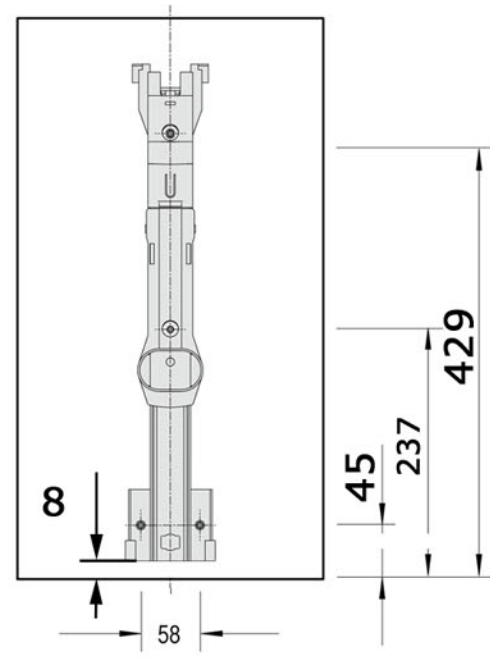
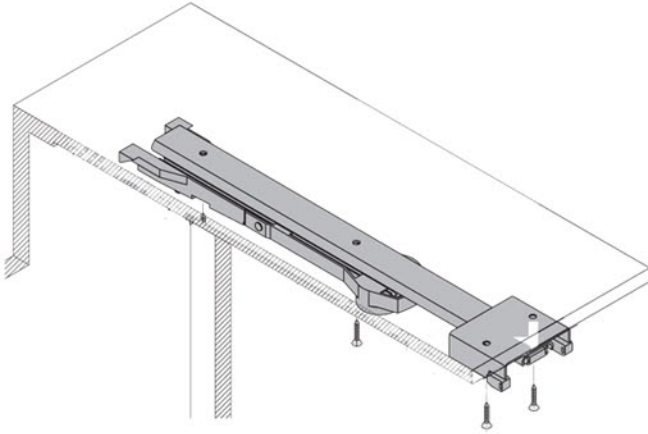

9

Effettuare regolazioni dell'anta
Go on adjusting the door
Faire les régulation de la façade

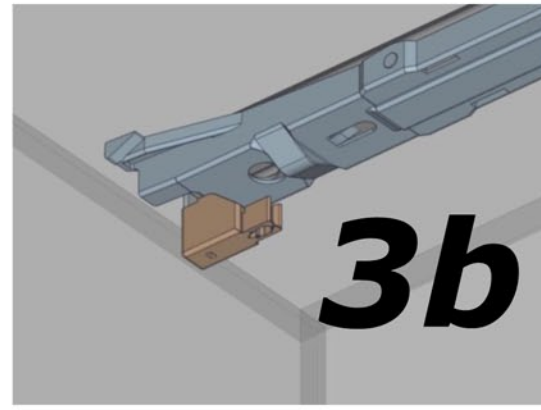
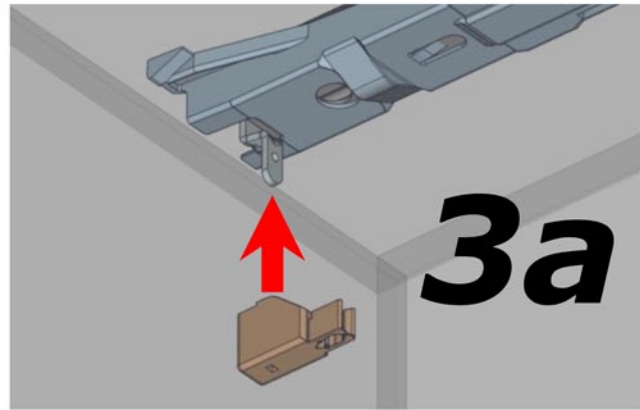
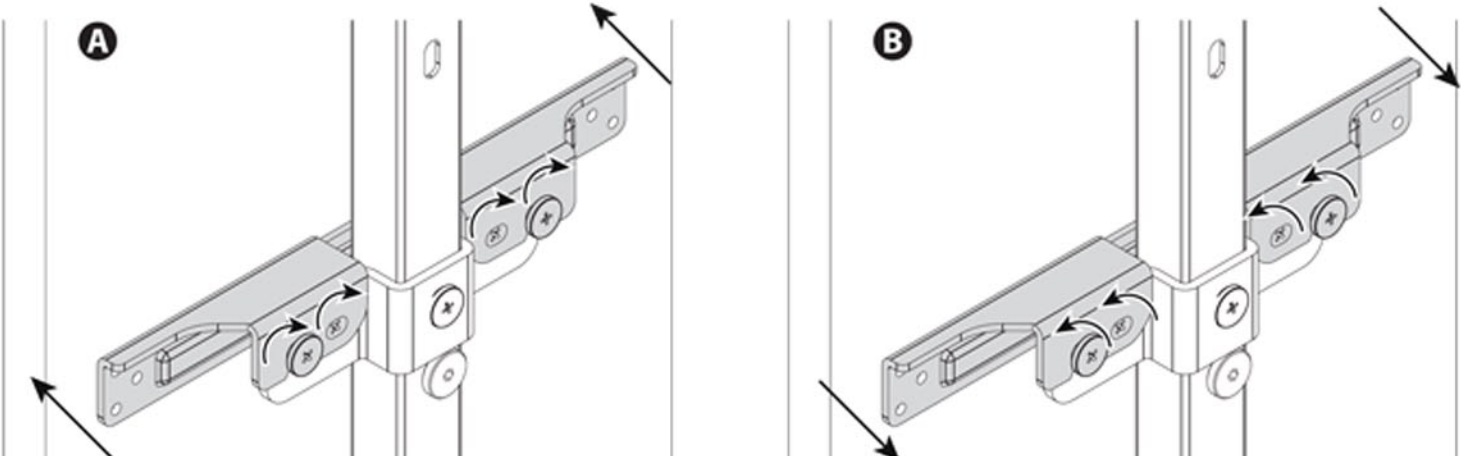

3

Montare il telaio **A** nella guida inferiore **C** aperta e serrare le viti (vedi figura 1)
Fix the frame **A** in the shallow bottom runner **C** open and tighten the screws (see the picture 1)
Assembler le châssis **A** sur la glissière inférieure **C** ouverte et bloquer les vis (voir l'image 1)

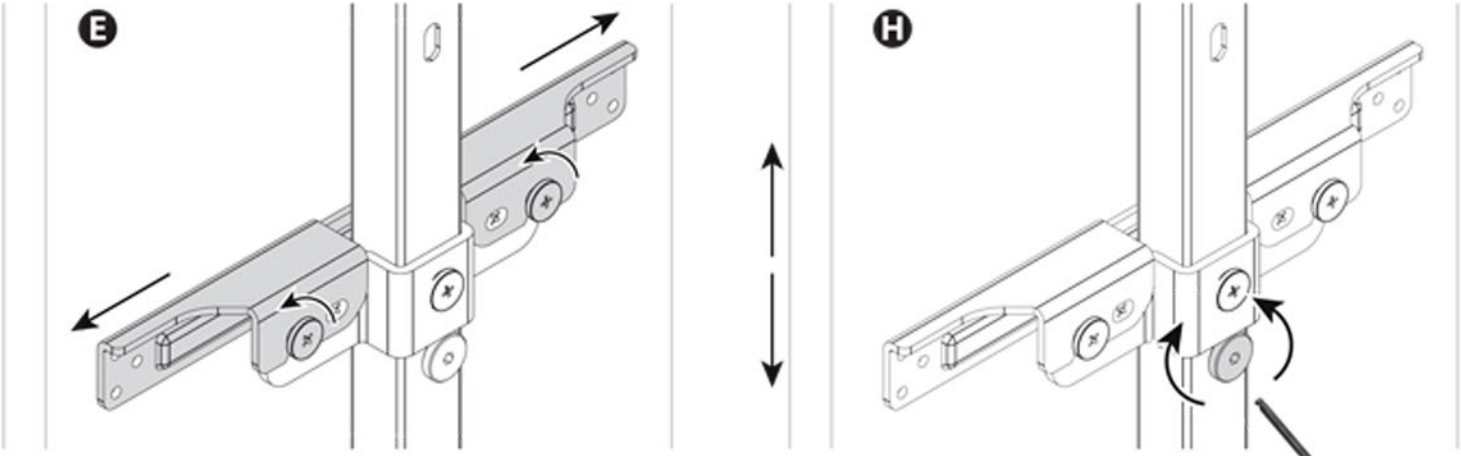
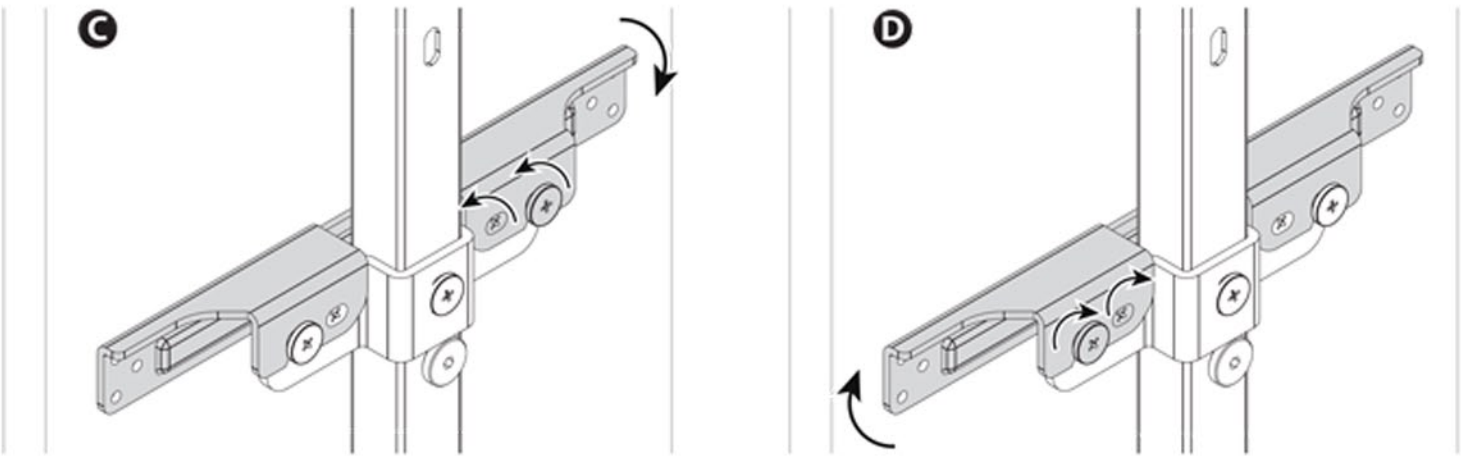
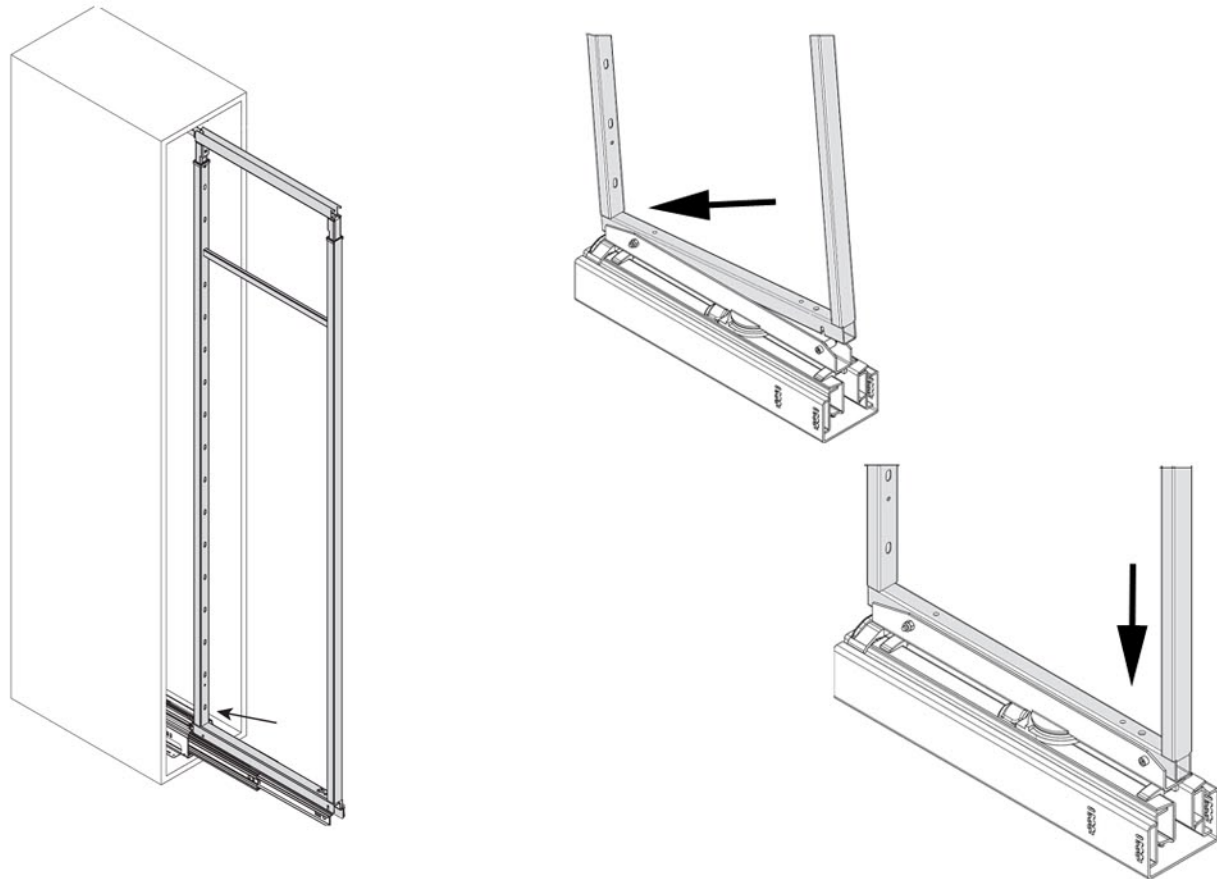

Per effettuare la regolazione **H** allentare tutte le viti di serraggio particolare **F** e agire sull'eccentrico posizionato in basso.
To mate the regulation **H** loosen all the screws of the fixing support **F** and work on the eccentric situated in the lower part.
Pour la régulation **H** deserrer toutes les vis de **F** et travailler sur l'excentrique situé en bas.

4

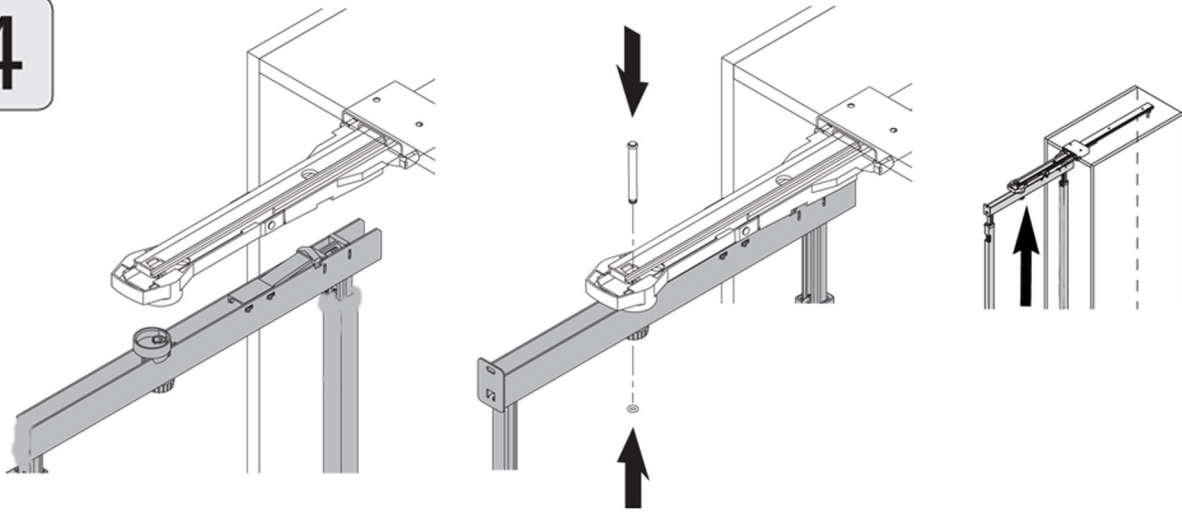

5

Disporre il telaio superiore **B** a misura e serrare con gli appositi grani (vedi figura 2)
 Set the upper frame **B** on the right distance and tighten with the screws provided (see the picture 2)
 Lever le châssis supérieur **B** à la correcte distance et la fixer avec les vis fournies (voir l'image 2)

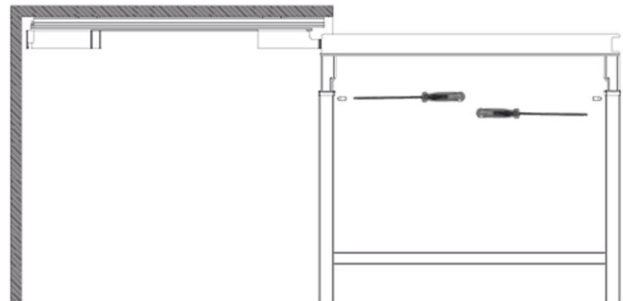
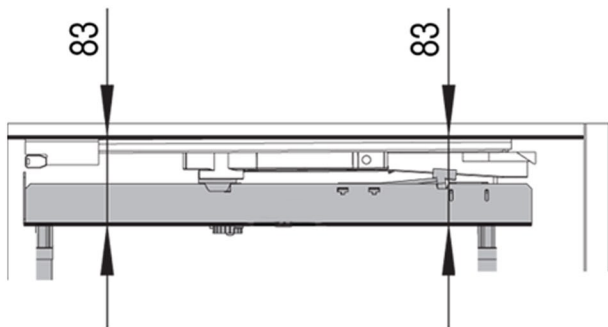

(Fig.2)

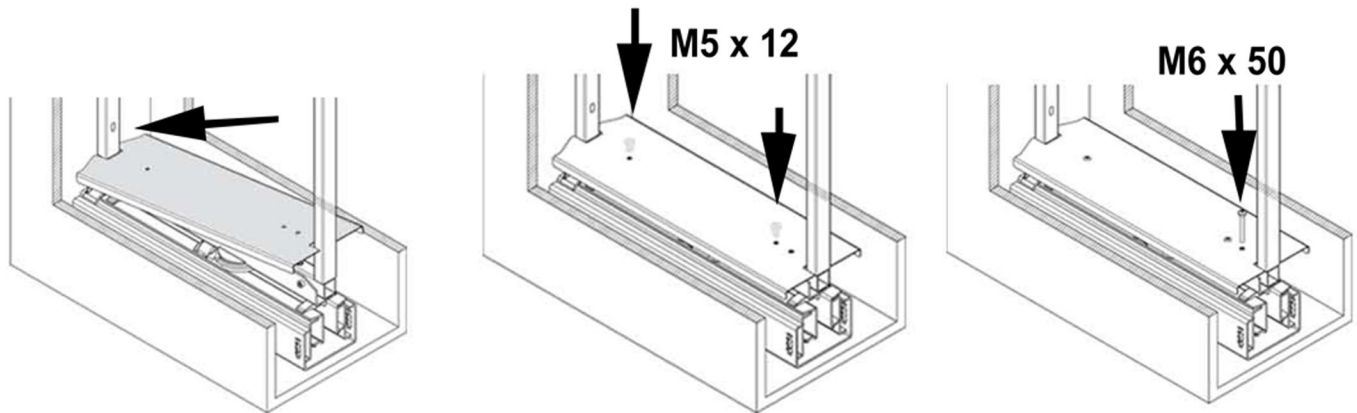

6

Inserire l'inserto speciale di serraggio **G** nelle asole del telaio **A** (come sequenza foto)
 Set the special fixing support **G** in the frame hole **A** (see the picture sequence)
 Insérer le support spécial de fixation **G** dans les trous du châssis **A** (voir l'image)

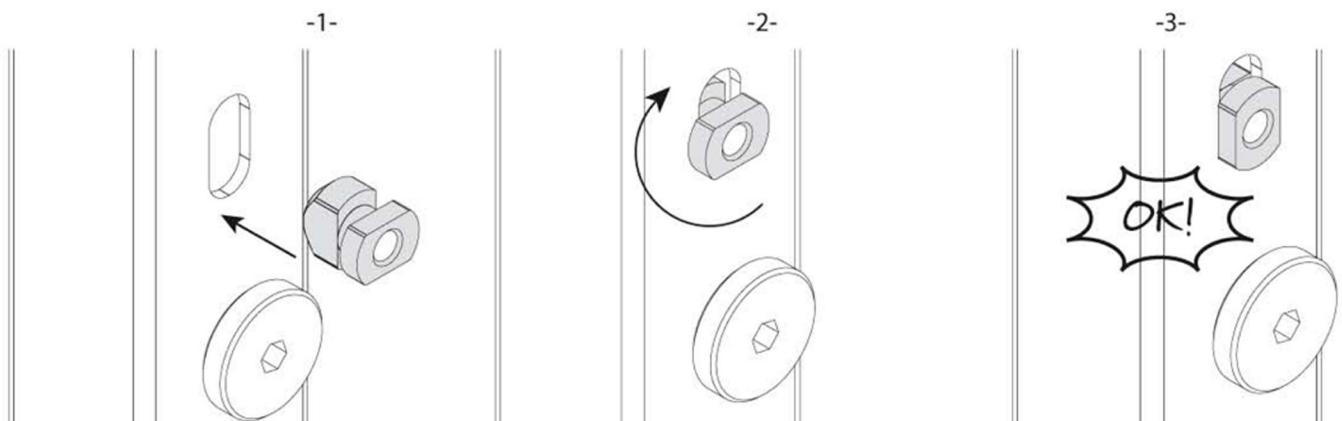

7

Posizionare i reggi attacco antina **F** e fissarli con l'apposita vite
 Set the door brackets frames **F** and fix with the special screw
 Positioner les équerres de châssis **F** et fixer par la vis speciale

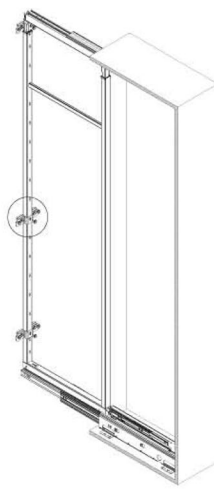
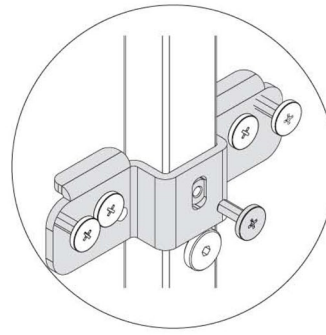

8

Montare le staffe attacco antina **E** sull'anta rispettando le quote e posizionarla sui reggi attacco antina **F** precedentemente montati
 Assemble the door bracket **E** on the door respecting the distances and set it on the door bracket frame **F**, already assembled.
 Fixer les équerres **E** sur la façade à la correcte distance et la accrocher sur l'équerre de châssis **F**.

